

M-D Pneumatics™ **EQUALIZER® DF**

Rotary Positive Blowers

Models: 4504 4506 4509 4512

Bi-directional Rotation

17 Series - Horizontal Air Flow

46 Series - Vertical Air Flow

Designed to be interchangeable with equivalent models from competing manufacturers, **EQUALIZER DF** rotary positive blowers from **Tuthill Vacuum & Blower Systems** offer many distinct advantages:

Higher Pressure Capability

Due to the high degree of precision to which **EQUALIZER DF** blowers are manufactured, most **EQUALIZER DF** models are rated to 18 PSIG discharge pressure. This provides you with an increased level of security since your **EQUALIZER DF** blower has more safety factor already built in.

Designed for True, Drop-in Replacement

The last thing you need is an "interchangeable" blower that really isn't. **EQUALIZER DF** blowers are designed to be dimensionally interchangeable with competing models, even to the point of matching the port connector bolt patterns.

Helical Gearing

EQUALIZER DF blowers are timed with hardened, precision helical gears that are keyed to the rotor shafts. Helical gearing reduces backlash and mechanical noise as compared to spur gears offered by other manufacturers. Keyed interference fit reduces the risk of slippage of the gear on the shaft and loss of timing, one of the leading causes of blower failure.

One Piece Housing

Every **EQUALIZER DF** blower includes a housing constructed of a single piece of precision machined cast iron, rather than a two piece housing which is subject to misalignment and loss of operating clearances.

Rotors with Integral Shafts

EQUALIZER DF blowers include precision machined and dynamically balanced ductile iron rotors with large, integrally cast shafts to provide single, unitized rotors to prevent clash as a result of the impeller moving on its shaft.

Individually Tested

Every **EQUALIZER DF** blower is factory tested to assure you of the highest quality. Tuthill Vacuum & Blower Systems goes the distance to insure that your blower meets our rigid ISO 9001 registered quality standards.

Positive End Clearances

End clearances are **positively established** at the blower gear end, eliminating the risk of shifting end clearances. End clearances are not "floating", and allowing incidental contact between rotors and end plates. "Floating" end clearances can result in unnecessary rotor and end plate wear, reducing flow performance and shortening overall blower life.

Polished Sealing Surfaces

All shaft surfaces in contact with sealing members are polished to reduce seal wear and risk of leakage.

ISO 9001 Registration

EQUALIZER blowers are manufactured under Tuthill Vacuum & Blower Systems' ISO 9001 registered quality assurance program, the first American manufacturer of rotary blowers to gain such international recognition.

Versatility

Flow configuration is completely field convertible from horizontal to vertical flow, or vice versa simply by rearranging oil breathers, drains and changing the mounting feet.

Material Specifications:

Housing: Cast iron

End Plates: Cast iron

End Covers: Cast iron

Rotors: Ductile iron

Shafts: Ductile iron cast integrally with rotors

Bearings: Gear end - Double row ball

Drive end - Cylindrical roller

Drive Shaft: Ductile iron cast integrally with drive rotor

Gears: Heat treated alloy steel, helical cut

Seals: Lip and piston ring labyrinth type on rotor shafts;

lip seal on the drive shaft

Lubrication: Oil splash system, both ends

Model Size	Max. Press. PSI	Max. Vac. (in. Hg)	Maximum RPM	Displ. CFR
4504	18	16	4000	.112
4506	18	16	4000	.164
4509	18	16	4000	.242
4512	15	16	4000	.321

LEADING THE SEARCH FOR NEW SOLUTIONS



TUTHILL
Vacuum & Blower Systems

4840 West Kearney Street, P. O. Box 2877
Springfield, Missouri USA 65801-2877
Tel 417 865-8715 800 825-6937 Fax 417 865-2950
<http://vacuum.tuthill.com>



Performance

Pressure performance is based on inlet conditions of 14.70 PSIA and 70° F.

Vacuum performance is based on inlet temperature of 70° F and discharge pressure of 14.70 PSIA.

In conjunction with our program of continuous testing and upgrading, all specifications are subject to change without notice.

All data are approximate. Request a quotation for your specific application.

Horizontal Flow (17 series)

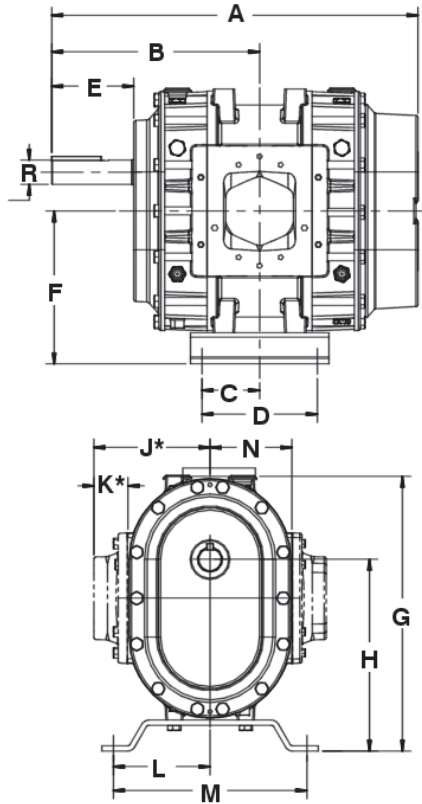

Blower Model	Replaces	Speed (RPM)	5 PSIG		8 PSIG		10 PSIG		12 PSIG		15 PSIG		18 PSIG		Max. Vacuum		
			CFM	BHP	CFM	BHP	CFM	BHP	CFM	BHP	CFM	BHP	CFM	BHP	" Hg	CFM	BHP
4504	DuroFlow® 4504	1150	62	3.9	44	5.6									11	41	4.2
		1750	129	6.0	111	8.5	101	10	92	12					13	95	7.2
		2950	263	10	246	14	235	17	226	20	214	24	203	29	16	207	14
		3500	325	12	307	17	297	20	288	24	276	29	265	34	16	269	17
		4000	381	14	363	20	353	23	344	27	332	33	321	39	16	325	19
4506	DuroFlow 4506	1150	105	5.2	82	7.7									11	79	5.6
		1750	203	8.0	181	12	168	14	157	17					14	152	10
		2950	400	13	378	20	365	24	354	28	339	35	325	41	16	330	19
		3500	491	16	468	23	456	28	444	34	429	41	415	49	16	420	23
		4000	573	18	551	27	538	33	527	38	511	47	497	55	16	502	26
4509	DuroFlow 4509	1150	170	7.2	142	11	125	13							12	127	8.3
		1750	316	11	287	16	271	20	256	24					15	238	15
		2950	607	18	578	28	562	34	547	40	527	50	509	59	16	516	27
		3500	740	22	711	33	695	40	680	48	661	59	643	70	16	649	32
		4000	861	25	832	38	816	46	802	55	782	67	764	80	16	770	37
4512	DuroFlow 4512	1150	240	9.2	206	14	187	17							13	175	11
		1750	433	14	399	21	380	26	362	31					15	340	20
		2950	819	24	784	36	765	44	748	52	724	65			16	710	35
		3500	996	28	961	43	942	52	924	62	901	77			16	887	42
		4000	1156	32	1122	49	1103	60	1085	71	1062	88			16	1048	48

Vertical Flow (46 series)

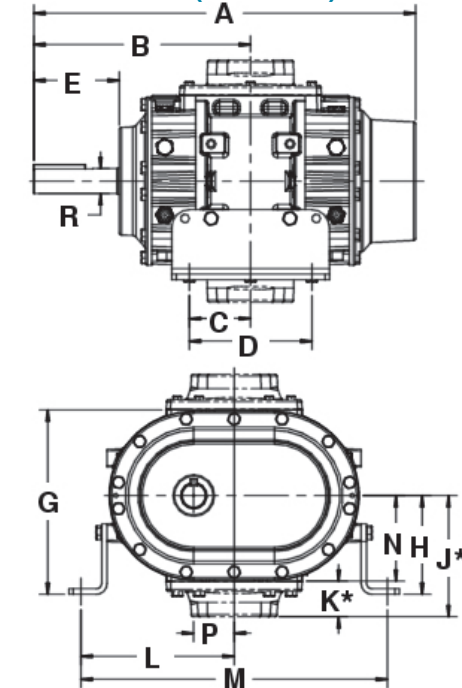

Dimensions

Model	Series	A	B	C	D	E	F	G	H	L	M	N	P	R	Wt. (lbs.)
4504	17	18.45	10.02	2.44	4.88	3.52	9.09	16.34	11.40	5.75	11.50	4.88	2.30	1.437	270
	46			2.50	5.00			—	10.50	5.63	8.75				
4506	17	21.82	12.39	3.44	6.88	4.89	9.09	16.34	11.40	5.75	11.50	4.88	2.30	1.437	310
	46			3.50	7.00			—	10.50	5.63	8.75				
4509	17	24.80	13.87	3.44	6.88	4.89	9.09	16.34	11.40	5.75	11.50	4.88	2.30	1.437	350
	46			3.50	7.00			—	10.50	5.63	8.75				
4512	17	27.81	15.38	4.94	9.88	4.89	9.09	16.34	11.40	5.75	11.50	4.88	2.30	1.437	390
	46			5.00	10.00			—	10.50	5.63	8.75				

Values shown are approximate and should not be used for construction.

Certified drawings are available through your local Tuthill Vacuum & Blower Systems Sales Professional.

Optional Port Connectors

Model	NPT	J*	K*	Wt. (lbs.) Each connector
4504	4"	9.02	4.15	11
	4" (short)	6.94	2.03	11
4506	4" (long)	10.94	6.03	19
	4" (short)	6.94	2.03	17
4509	5" (short)	12.47	2.93	15
	5" (long)	7.84	12.47	28
4512	6" (short)	7.63	2.72	19
	6" (long)	13.19	8.28	36

Your Local Tuthill Vacuum & Blower Systems Sales Professional:



TUTHILL
Vacuum & Blower Systems

4840 West Kearney Street, P. O. Box 2877
Springfield, Missouri USA 65801-2877
Tel 417 865-8715 800 825-6937 Fax 417 865-2950
<http://vacuum.tuthill.com>

