

# AQUA DECANT™

## FLOATING DECANTER SYSTEMS

- ☑ Designed to cause minimal disturbance of the sludge blanket, which can save sedimentation time
- ☑ Simple and robust equipment
- ☑ Manufactured in stainless steel
- ☑ Simple and easy installation
- ☑ Floating execution
- ☑ Designed to work with water level variations
- ☑ Discharges the clear supernatant after the settling cycle
- ☑ Avoids the aspiration and discharge of floatable materials
- ☑ Ideal solution for SBR reactors
- ☑ Flow range from 10 to >2.000 m<sup>3</sup>/h
- ☑ Adjustable flow
- ☑ 4 possible executions
  - Decanting with discharge by gravity
  - Decanting with discharge by pump
  - Decanting with mechanically closing system and discharge by gravity
  - Decanting with mechanically closing system and discharge by pump

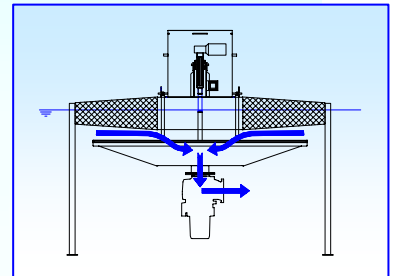
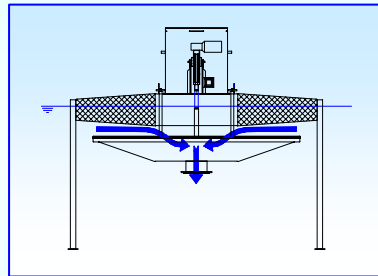
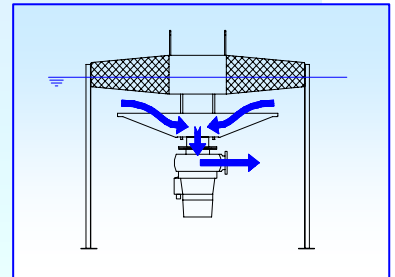
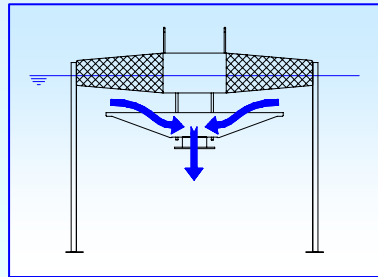

## AQUA DECANT™ floating weir with discharge by gravity

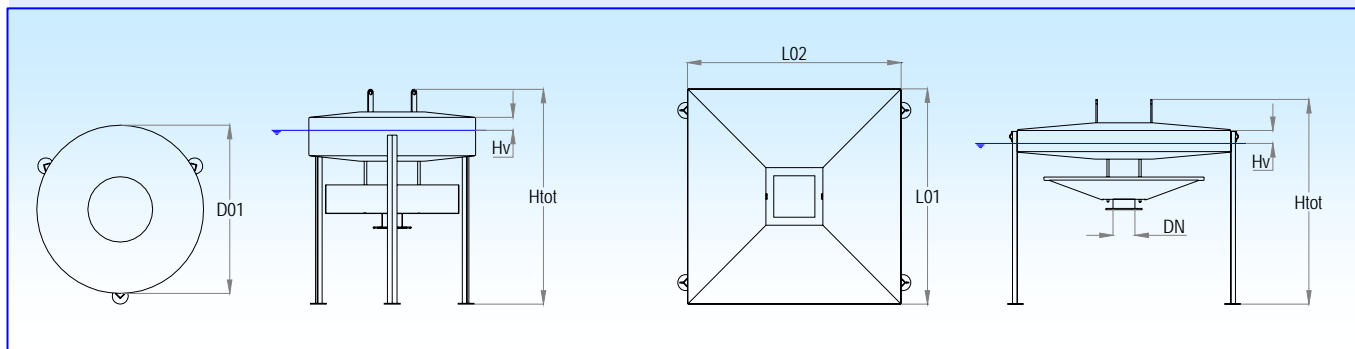

TYPE AD	FLANGE CONNECTION	D01 [mm]	L01 [mm]	L02 [mm]	Hv [mm]	H <sub>TOTAL</sub> * [mm]	MASS approx. [kg]
AD 50-G	DN40 - DN80	750	---	---	100	1300	80
AD 150-G	DN80 - DN150	1250	---	---	120	1600	150
AD 300-G	DN150 - DN250	---	2000	2000	120	2000	430
AD 800-G	DN250 - DN350	---	2300	2300	120	2000	580
AD 1500-G	DN300 - DN...	---	2290	3500	180	2490	820

## AQUA DECANT™ floating weir with discharge by pump

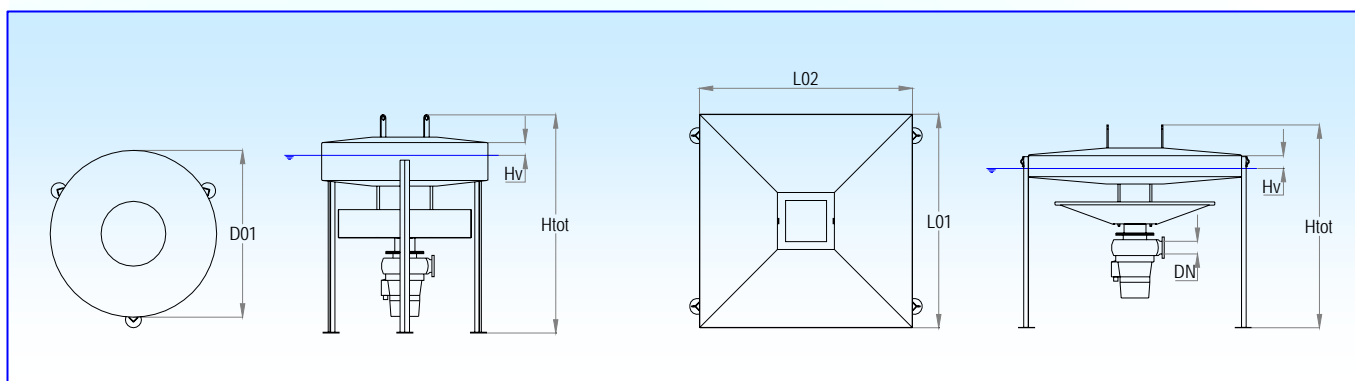

TYPE AD	FLANGE CONNECTION	D01 [mm]	L01 [mm]	L02 [mm]	Hv [mm]	H <sub>TOTAL</sub> * [mm]	MASS** approx. [kg]
AD 50-3/6	DN40 - DN80	750	---	---	60	1500	170
AD 150-3/6	DN80 - DN150	1250	---	---	80	1800	300
AD 300-3/6	DN150 - DN250	---	2000	2000	80	2500	1130
AD 800-3/6	DN250 - DN350	---	2300	2300	80	2500	1280
AD 1500-3/6	DN300 - DN...	---	2290	3500	100	2800	2300

\* Depends on the kind of discharge system - Extended supports are possible to stand on the basin floor at min. WL.

\*\* Depends on the kind of pump.

All values are indicative. AQUASYSTEMS INTERNATIONAL NV reserves the right to adjust these values at any time.

## AQUA DECANT™ floating mechanically closing weir with discharge by gravity

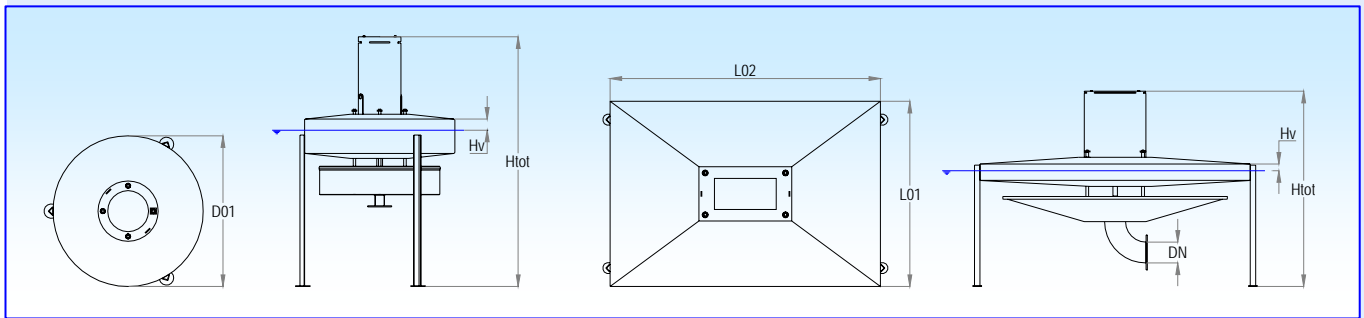

TYPE AD	FLANGE CONNECTION	D01 [mm]	L01 [mm]	L02 [mm]	H <sub>v</sub> [mm]	H <sub>TOTAL</sub> * [mm]	MASS approx. [kg]
ADMC-A 150-G	DN80 - DN150	1250	---	---	120	2100	190
ADMC-A 300-G	DN150 - DN300	---	2000	2000	130	2500	610
ADMC-A 800-G	DN300 - DN350	---	2300	2300	140	2580	740
ADMC-A 1500-G	DN350 - DN400	---	2290	3500	150	3100	835

## AQUA DECANT™ floating mechanically closing weir with discharge by pump

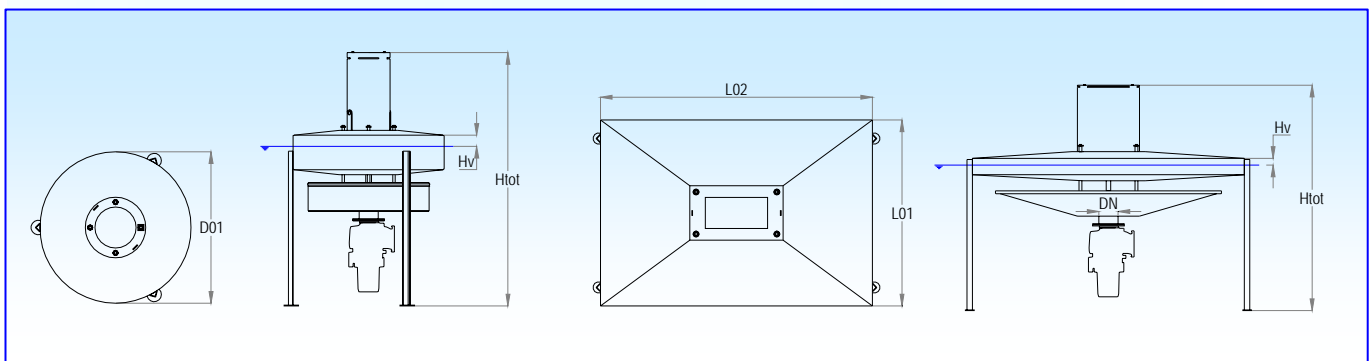

TYPE AD	FLANGE CONNECTION	D01 [mm]	L01 [mm]	L02 [mm]	H <sub>v</sub> [mm]	H <sub>TOTAL</sub> * [mm]	MASS** approx. [kg]
ADMC-A 150-3/6	DN80 - DN125	1250	---	---	120	2100	340
ADMC-A 300-3/6	DN125 - DN200	---	2000	2000	130	2500	860
ADMC-A 800-3/6	DN200 - DN250	---	2300	2300	140	2580	1440
ADMC-A 1500-3/6	DN250 - DN300	---	2290	3500	150	3100	1735

\* Depends on the kind of discharge system - Extended supports are possible to stand on the basin floor at min. WL.

\*\* Depends on the kind of pump.

All values are indicative. AQUASYSTEMS INTERNATIONAL NV reserves the right to adjust these values at any time.

# AQUA DECANT™ discharge systems

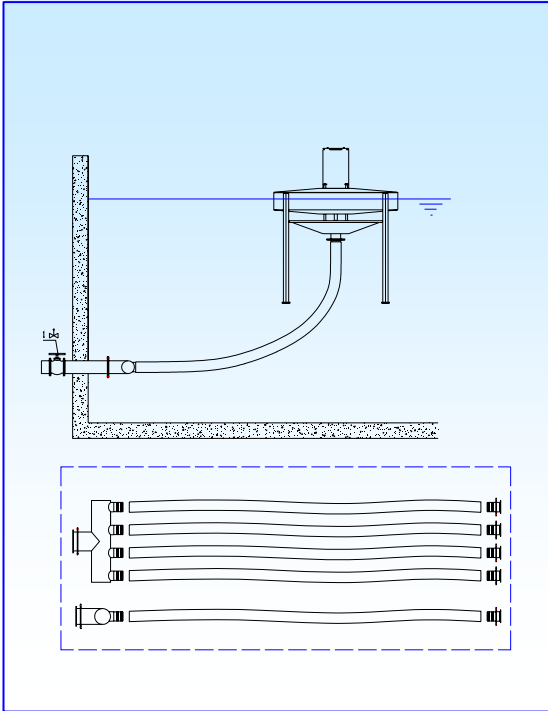

Flexible hose up to DN150 or  
Multiple flexible hoses (DN150)  
with collector up to DN300

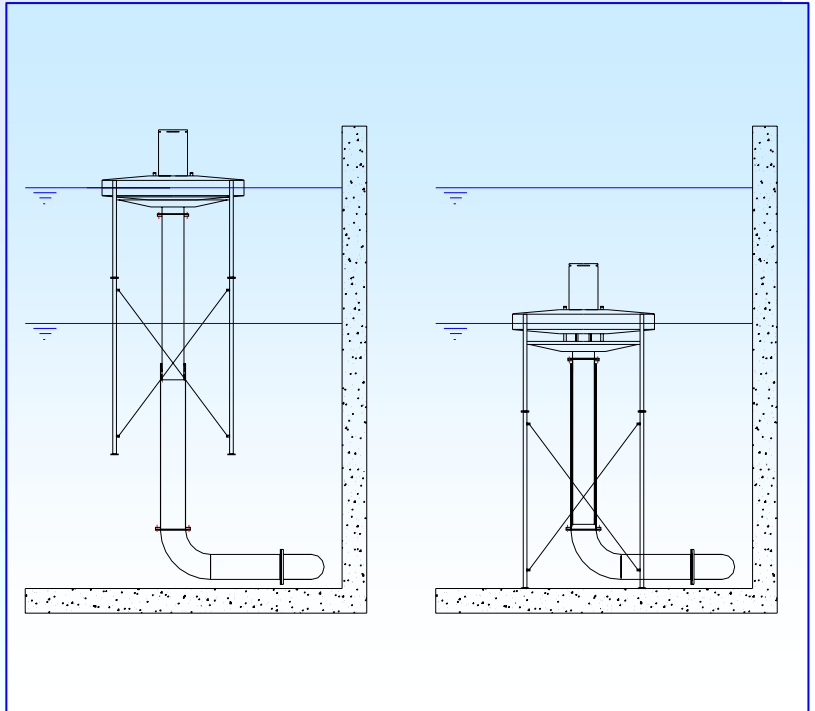

Telescopic discharge pipe up to DN450

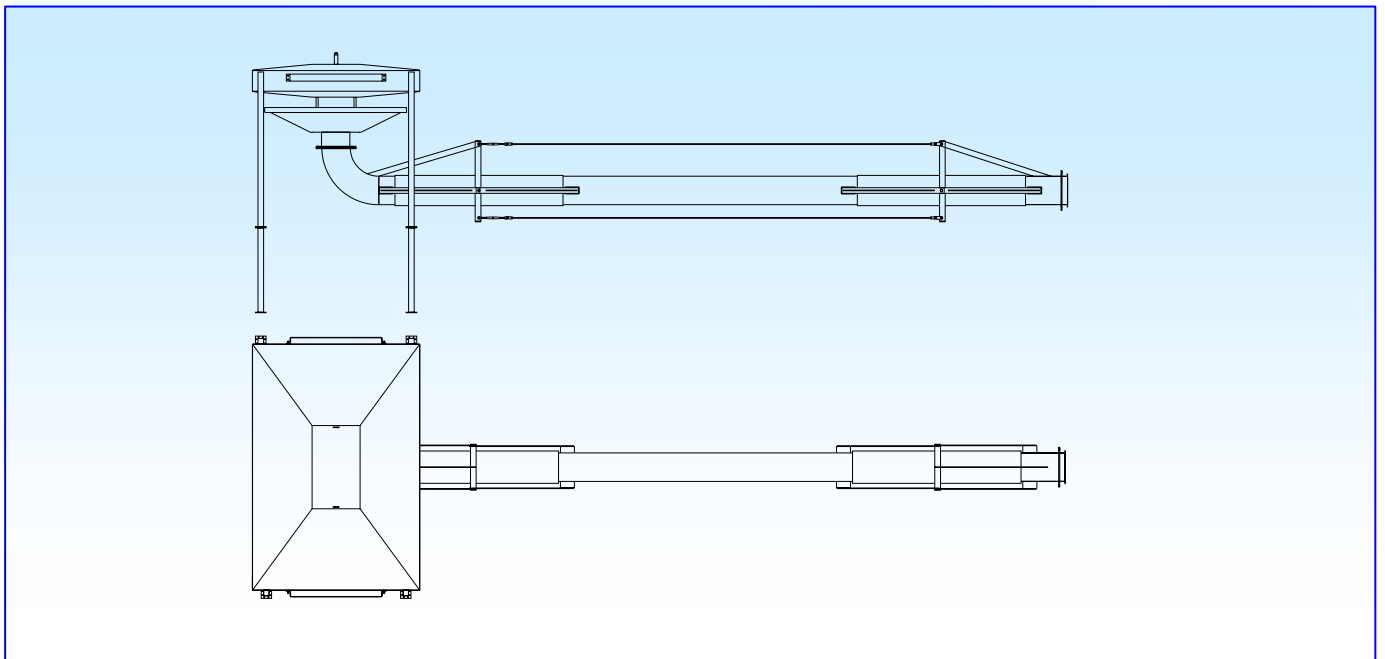

Hinged discharge system up to DN450

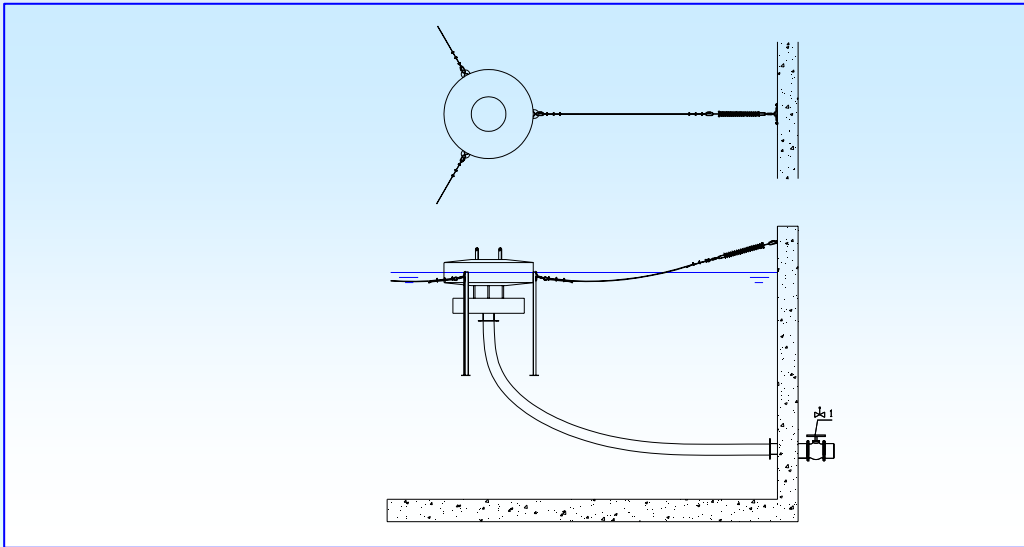

Mooring with cables and compression springs

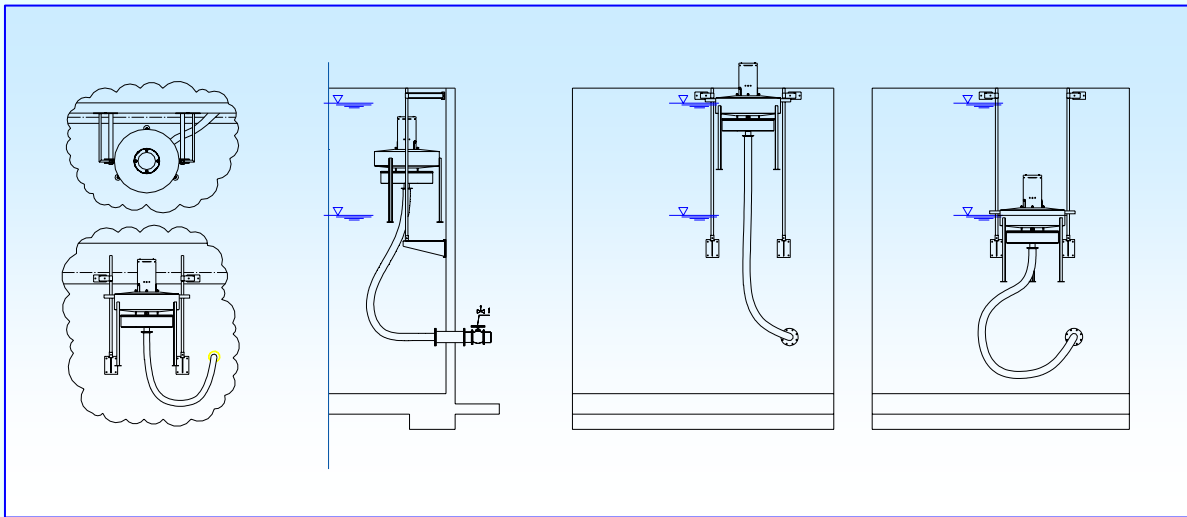

Mooring with vertical guiding posts on the side of the basin

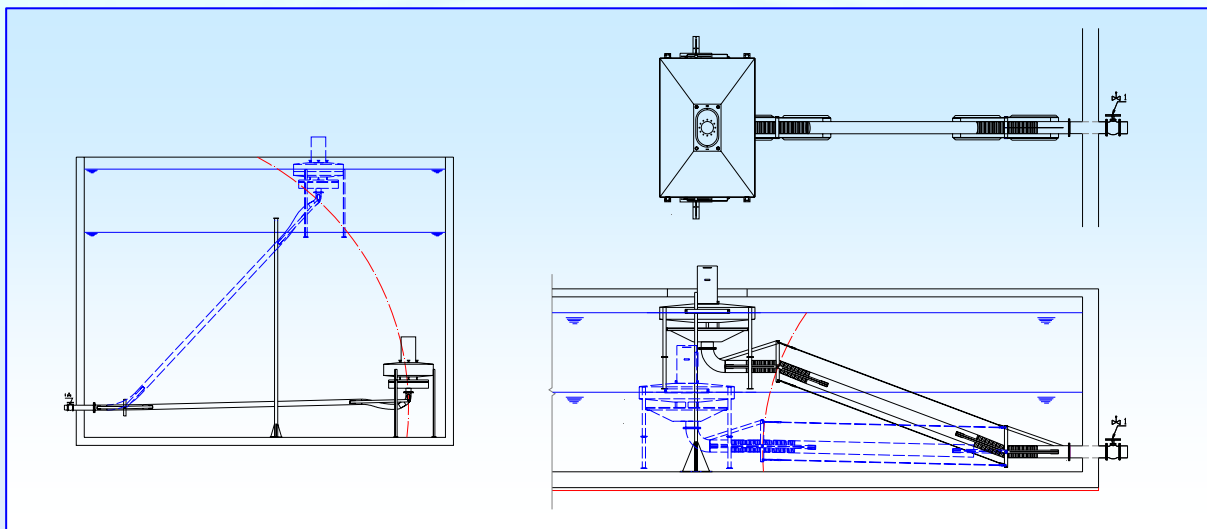

Mooring with hinged discharge system and vertical guiding post on the bottom of the basin

## Mechanically Closing Decanter with hinged discharge system

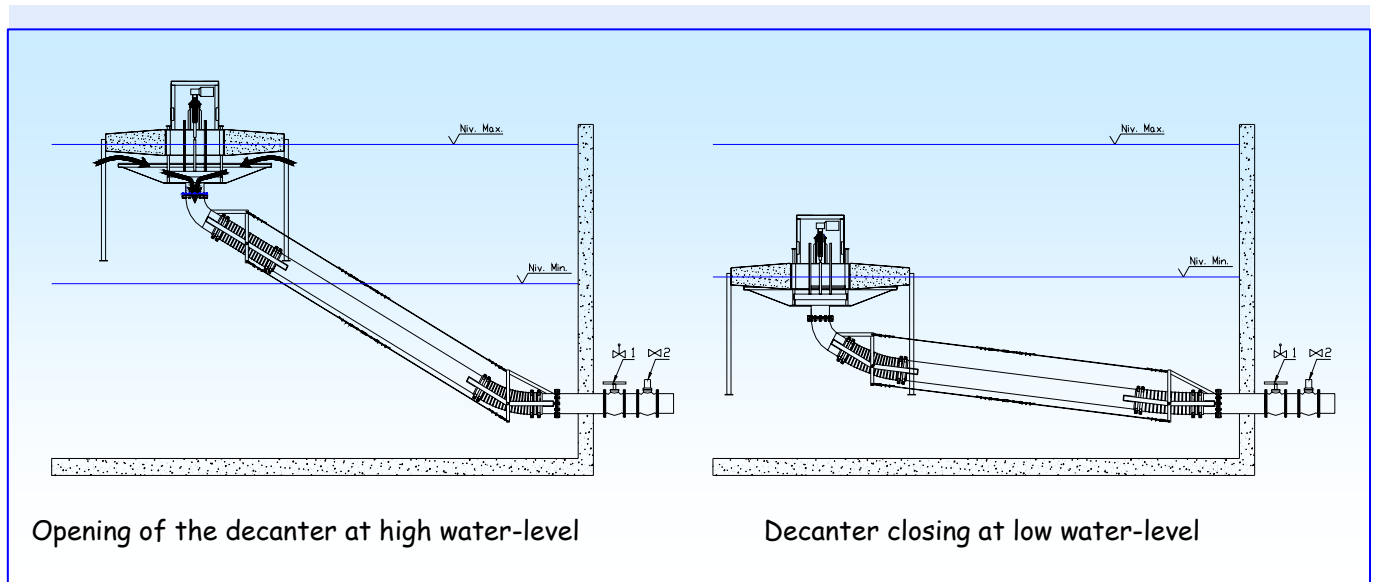

## Description of the closing system and the flow regulation

- The Decanter with a Mechanically Closing system is equipped with a motorised Actuator, to open or close the gap between the overflow weir and the float.
- The discharge stops when valve 1 outside the basin is closed (this valve is never included in our supply).
- The opening between the weir and the float (to prevent sludge from entering) may only be closed after valve 1 has been closed.
- The discharge system by gravity produces a flow which will vary with the water level; to limit the extent of these flow variations, one should install an additional valve downstream (see valve 2 above).

### Headquarters

**AQUASYSTEMS INTERNATIONAL NV**  
Brusselssteenweg 508 • B-1500 Halle - Belgium  
Tel.: +32-(0)2-362.02.62 • Fax: +32-(0)2-360.35.89  
e-mail: [asi@aquaturbo.be](mailto:asi@aquaturbo.be) • <http://www.aquaturbo.be>

### Subsidiary

**AQUATURBO SYSTEMS INC. - USA**



**AQUASYSTEMS INTERNATIONAL NV**  
Sales Offices

UK • GERMANY • SWEDEN • ROMANIA • FRANCE

*World-wide network of distributors and agents*